

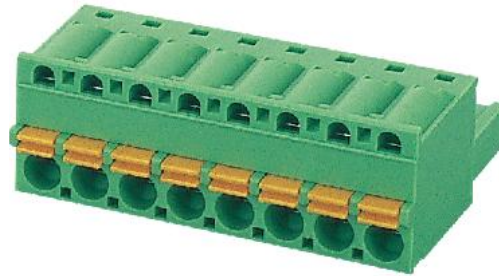

# DEGSON ELECTRONICS CO., LTD.

## Product Specification



**2EDGKD-5.0**  
**2EDGKD-5.08**

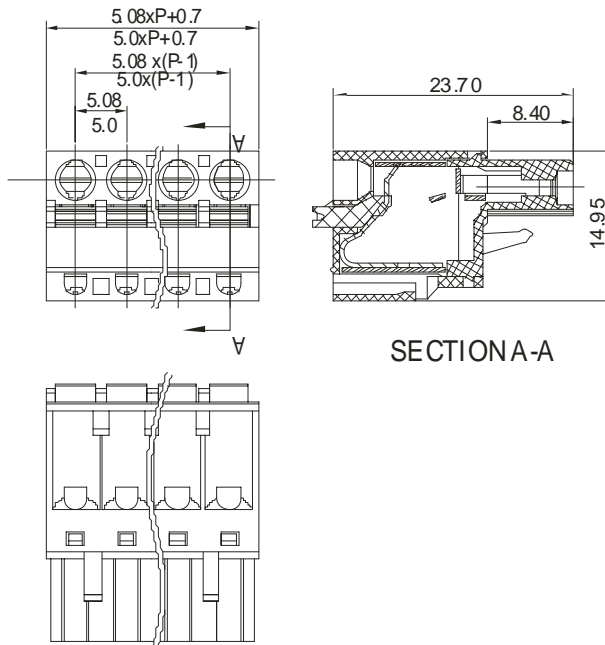

<b>APPROVAL</b>		
<b>Electrical</b>		
Standard	<b>UL</b>	<b>IEC</b>
Rated voltage	300V	320V
Rated current	10A	20A
Wire range	26-12AWG	2.5mm <sup>2</sup>
Withstanding voltage	AC2500V/1Min	
<b>Mechanical</b>		
Torque	-40°C ~ +105 °C	
Ambient temperature	10mm	
Strip length		
<b>Dimensions</b>		
Pitch	5.0mm(.197" ) 5.08mm(.200" )	
Poles	2P-16P	
<b>Material</b>		
Housing	PA66,UL94 V-0	
Contact	Phosphor bronze	
Wire guard	Stainless steel	

### HOW TO ORDER :

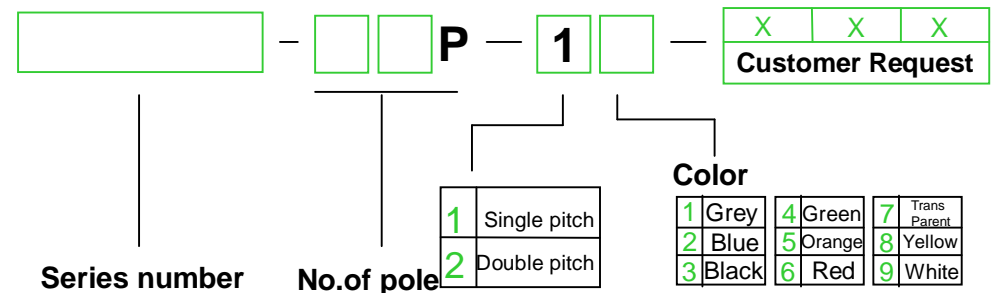

 mm (INCH)	 <b>DEGSON ELECTRONICS CO., LTD.</b>
 THROANGLE PROJECTION	<b>NAME</b> <b>2EDGKD-5.0 2EDGKD-5.08</b>