

5. General Specifications:

CURRENCY AND INTERFACES See Software Description document

ELECTRICAL SPECIFICATION:

Operating Voltage	Maximum Operating Current	Maximum Current
12 V DC	1.0 A	2.0 A

Use only current limiting CSA or UL recognized CLASS 2 Power Supply.

OPERATING TEMPERATURE: -0 to +50 degrees Celsius

TOTAL WEIGHT: WITHOUT CASSETTE: < 4.2 kg

CASSETTE WEIGHT: 1.8 kg

FEATURES: Multi-Width Validating Head
Bracket for optional Lock for the cassette
End Switch for the cassette and cassette Lock

ENCLOSURE: MFL Bill Validator
User's Guide
Software description
MK JAE Connector: Part # OPT-MKFL-JAE
MK (M)FL Housing with Lock: Part # OPT-MKFL-FLH

OPTIONAL ACCESSORIES AND DOCUMENTS:

Sensor Box Extractor: Part # OPT-HW-FT01

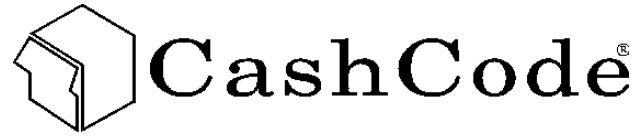

FL Bill Validator

User's Guide

Front Loaded Bill Validator

Hardware part # **MFL-0386**

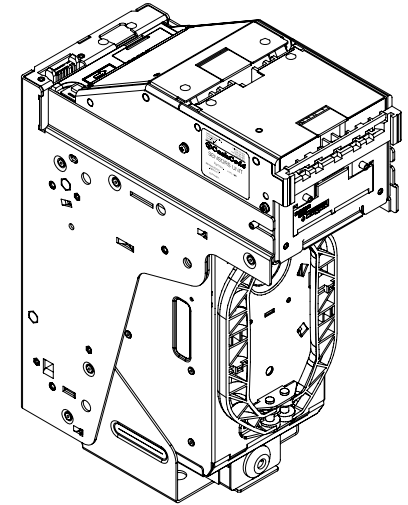

The Part Number on the Label includes Hardware Part Number and Software Part Number.

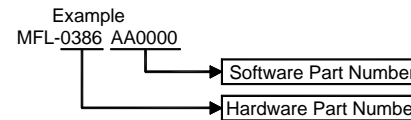

1. Assembly MFL-0386 contents

Unit	Unit Part No.:	Unit Description	
Validating Head	MFLV-2110	Multi-Width Validating Head	
Power Interface	FLP-1710	12V DC, Opto Isolated, Platform A	
Sense -A- Click	FLS-1704	FLS-1704U	Set of Basic Sense-A-Click sensor packs;
		FLS-1704L	
Housing	FLH-0810	Optional bracket for the cassette Lock; Switch for the cassette and cassette lock; JAE connector;	

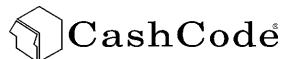

CashCode Company Inc.
553 Basaltic Rd. Concord, Ontario Canada. L4K 4W8
TEL: (905) 303-8874 (800)-584-2633
FAX: (905) 303-8875 (800)-593-2633

2. Typical DIP Switches and Jumpers Setting

To access switches and jumpers on the CPU board pull out Validating Head, open transparent cover at rear side of the Validating Head. The data in the chart is example only. See Software Description document for exact switches and jumpers settings.

SW. #1	ON State	OFF State	Default Setting
SW 1.1	1-st Bill Enable	1-st bill Disable	ON
SW 1.2	2-nd Bill Enable	2-nd Bill Disable	ON
SW 1.3	3-rd Bill Enable	3-rd Bill Disable	ON
SW 1.4	4-th Bill Enable	4-th Bill Disable	ON
SW 1.5	5-th Bill Enable	5-th Bill Disable	ON
SW 1.6	6-th Bill Enable	6-th Bill Disable	ON
SW 1.7	7-th Bill Enable	7-th Bill Disable	ON
SW 1.8	8-th Bill Enable	8-th Bill Disable	ON

SW#2	ON State	OFF State	Default Setting
SW 2.1	Four Way	One Way	ON
SW 2.2	Reserved	Reserved	ON
SW 2.3	9 600 bps	19 200 bps	ON
SW 2.4	Service	To work with a "Host Machine Controller"	OFF

3. Interface Connector Pinout

Mating Connector:

Socket DR-12-2SC-FO (JAE);

Contact DR-SC20-1-7000 (JAE).

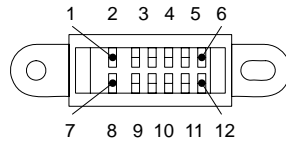

Terminal	Circuit
1	+12 V
2	M.RES
3	+12 V (INTERFACE)
4	GND
5	LED +
6	NC
7	GND
8	TXD
9	RXD
10	NC
11	LED -
12	NC

4. Diagnostics

Count the number of flashes and compare with the diagnostic chart below:

## of flashes	Malfunction
1 red on black	Cassette is out of position
2 red on black	Wrong Sense-A-Click type or communication with Sense-A-Click failed.
3 red on black	Cassette is full
4 red on black	Mechanical jam in the cassette (stacking motor can not stack the bill)
5 red on black	Failure of capacitance sensors
6 red on black	Failure of optical sensors
7 red on black	Failure of magnetic sensors
8 red on black	Transporting motor failure (timeout)
9 red on black	Speed of transporting motor is too fast
10 red on black	Failure of Aligning motor or sensor
11 red on black	Bill pathway latch is not empty (bill is jam)
12 red on black	Banknote jammed in the entry slot of the cassette and credit were not issued
13 red on black	Transport Motor overload
1 green on red	COM port CRC Error
2 green on red	Internal CRC Error
3 green on red	Improper CCMS format
4 green on red	CCMS is absent
5 green on red	Improper type of CCMS
6 green on red	Download Error